

REDLC125

INSTRUCTION MANUAL
MANUAL DE INSTRUCCIONES
MANUEL D'INSTRUCTIONS

- ✓ Reduce
- ✓ Reuse
- ✓ Recycle

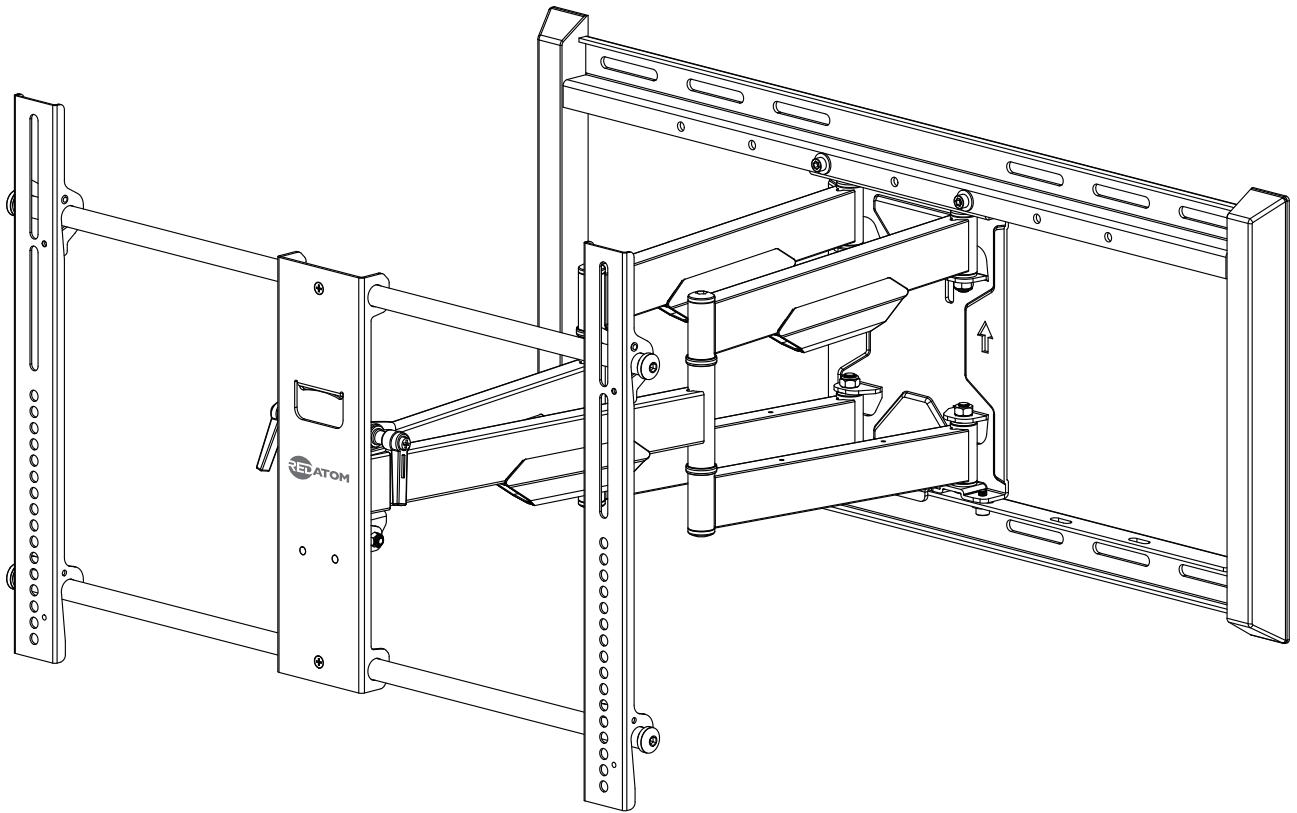

⚠ CAUTION: THE MAXIMUM LOADING WEIGHT IS 130 LBS. USE WITH PRODUCTS HEAVIER THAN THE MAXIMUM WEIGHT INDICATED MAY RESULT IN INSTABILITY AND POSSIBLE PERSONAL INJURY.

Max Screen Size: 80"

QUESTIONS?

NEED HELP?

info@redatomproducts.com



DISCLAIMER – WARNING INFORMATION

Disclaimer – RED ATOM™ has extended every effort to ensure to accuracy and completeness of this manual. However, RED ATOM does not claim that the information covers all installation and or operational variables. The information contained in this document is subject to change without notice or obligation of any kind. Regarding the information contained herein, RED ATOM makes no representation of warranty, expressed or implied, and assumes no responsibility for accuracy, sufficiency, or completeness of the information contained in this document.

WARNING: FAILURE TO READ, THOROUGHLY UNDERSTAND, AND FOLLOW ALL INSTRUCTIONS CAN RESULT IN SERIOUS PERSONAL INJURY, DAMAGE TO PERSONAL PROPERTY, OR VOIDING OF FACTORY WARRANTY!

It is the responsibility of the installer to ensure all components are properly assembled and installed using the instructions provided. If you do not understand these instructions or have any questions or concerns, please contact customer service at info@redatomproducts.com

Do not attempt to install or assemble this product if the product or hardware is damaged or missing. The included hardware is designed for use on vertical walls constructed of wood studs or solid concrete. A wood stud wall is defined as consisting of a minimum of 2x4 wooden studs (2" wide by 4" deep) with a maximum of 5/8" drywall. The included hardware is not designed for use with metal studs or cinderblock walls. If you're uncertain about the construction of your wall, then please consult a qualified contractor or installer for assistance. For a safe installation, the wall you are mounting to must support 4 times the weight of the total load. If not, then the surface must be reinforced to meet this standard. The installer is responsible for verifying that the wall structure and hardware used in any installation method will safely support the total load.

ESPAÑOL

Descargo de responsabilidad. RED ATOM™ procura que este manual sea preciso y completo. No obstante, no garantiza que la información aquí incluida cubra todos los detalles, condiciones o variantes. Tampoco prevé todas las posibles contingencias relacionadas con la instalación o el uso de este producto. La información que contiene este documento queda sujeta a cambio sin aviso previo o compromiso alguno. RED ATOM no ofrece ninguna garantía, ni expresa ni implícita, respecto de la información aquí incluida. RED ATOM no se responsabiliza de la precisión de la información prevista en este documento, ni tampoco de que sea completa o suficiente.

Soportes de pared

ADVERTENCIA: NO LEER, ENTENDER CABALMENTE Y SEGUIR TODAS LAS INSTRUCCIONES PUEDE DERIVAR EN LESIONES GRAVES, DAÑOS MATERIALES O LA NULIDAD DE LA GARANTÍA OTORGADA POR EL FABRICANTE.

Es responsabilidad del instalador comprobar que todos los componentes estén correctamente ensamblados e instalados según las instrucciones provistas. Si usted no entiende estas instrucciones o si tiene dudas o preguntas, comuníquese con Atención al Cliente por teléfono al por escrito a info@redatomproducts.com.

No instale ni ensamble el producto si éste o las piezas suministradas presentaran daños o si faltara algún elemento. Las piezas incluidas están diseñadas para ser instaladas en paredes con TVes de madera o en paredes de hormigón. Se define como pared con montantes de madera aquella conformada por montantes de madera de 51 mm (2 pulgadas) de ancho por 102 mm (4 pulgadas) de profundidad como mínimo y por TVes de yeso de 16 mm (5/8 pulgada) de espesor como máximo. Las piezas incluidas no están diseñadas para instalarse en paredes con montantes de metal ni en paredes de bloques de hormigón. Si tiene dudas acerca del tipo de pared que tiene usted, consulte a un contratista o a un instalador calificado. Para realizar una instalación segura, la pared elegida debe poder soportar cuatro veces el peso de la carga total. De lo contrario, deberá reforzar la superficie para que cumpla con este requisito. El instalador es el responsable de comprobar que la estructura de la pared y las piezas utilizadas en la instalación soporten la carga total de manera segura.

FRANÇAIS

Dénégation de responsabilité – RED ATOM™ vise l'exactitude et la complétude du présent manuel, toutefois, ne prétend en aucun cas que les informations contenues dans le présent document couvrent tous les détails, conditions ou variations. L'entreprise ne prévoit pas non plus tous les cas de figures possibles liés à l'installation ou à l'utilisation de ce produit. Les informations contenues dans le présent document sont sujettes à modification sans préavis, ni obligation quelconque. RED ATOM ne fait aucune déclaration quant à une garantie expresse ou implicite concernant les informations contenues dans le présent document. RED ATOM n'est en aucun cas responsable de l'exactitude, de l'exhaustivité, ni de la suffisance des informations contenues dans le présent document.

Supports muraux

ATTENTION : SI VOUS NE LISEZ, NI NE COMPRENEZ, NI NE SUIVEZ SOIGNEUSEMENT TOUTES CES INSTRUCTIONS, IL POURRAIT S'ENSUIVRE DES BLESSURES GRAVES, DES DOMMAGES MATÉRIELS OU L'ANNULATION DE LA GARANTIE!

L'installateur est responsable de s'assurer de l'exactitude de l'assemblage et de l'installation de toutes les composantes, conformément aux instructions fournies. Si vous ne comprenez pas ces instructions ou pour toute question ou problème, veuillez contacter le service à la clientèle au info@redatomproducts.com.

Si le produit est endommagé ou que des fixations sont manquantes ou endommagées, n'installez pas le produit. Si vous avez besoin de pièces ou de quincaillerie de rechange, veuillez contacter le Service à la clientèle au Info@redatomproducts.com. La quincaillerie fournie est conçue pour servir sur des parois verticales en bois ou en béton massif. Un mur à poteau en bois est défini comme constitué au minimum de poteaux de 2x4 (51 mm ou 2 po de large par 102 mm ou 4 po de profondeur) avec un maximum de 16 mm (5/8 po) de cloison sèche. La quincaillerie incluse n'est pas conçue pour servir sur des poteaux métalliques, ni des murs en briques de mâchefer. Si vous n'êtes pas sûr de la construction de votre mur, veuillez consulter un maître d'œuvre ou installateur qualifié pour obtenir de l'aide. Pour que l'installation soit sécuritaire, le mur d'installation doit pouvoir supporter 4 fois le poids de la charge appliquée. Si tel n'est pas le cas, la surface doit être renforcée en conséquence. L'installateur doit s'assurer que la structure du mur et la quincaillerie utilisée pour n'importe quelle méthode de fixation peuvent supporter sans danger le poids de tous les équipements.

TOOLS NEEDED

Herramientas Necesarias

Outils Requis

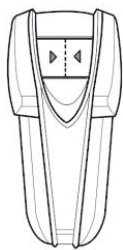
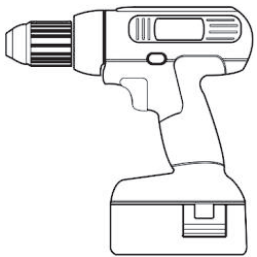

7/32"
5.5 mm



3/8"
10 mm



SYMBOLS



Drill
Agujerear
Percer



Level
Nivel
Niveau



Socket Wrench
Llave española
Clé ouverte



Caution
Precaución
Attention

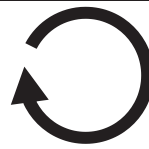

Tighten
Ajustar
Serrer



Pencil Mark
Marque con lápiz
Marque de crayon



Screwdriver
Destornillador
Tournevis



Heavy!
Tres Lourd!
!Pesado!

HARDWARE PRODUCT NUMBERS

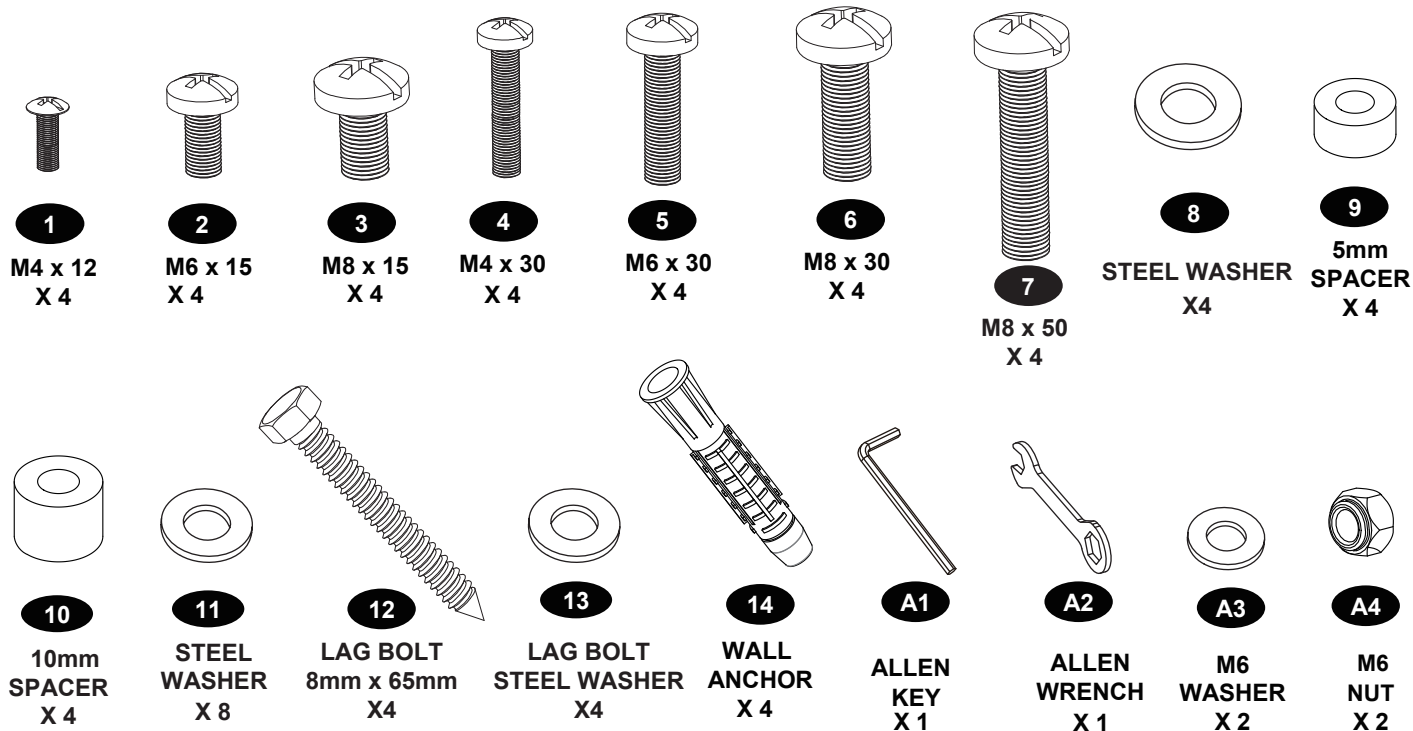

BEFORE INSTALLING! CONFIRM YOUR TV MOUNTING HOLE PATTERN WILL WORK WITH THIS MOUNT

TV Mounting Pattern (W x H)
Minimum: 200mm x 100mm (W X H)
Maximum: 600mm x 400mm (W X H)

PRODUCT COMPONENT PARTS

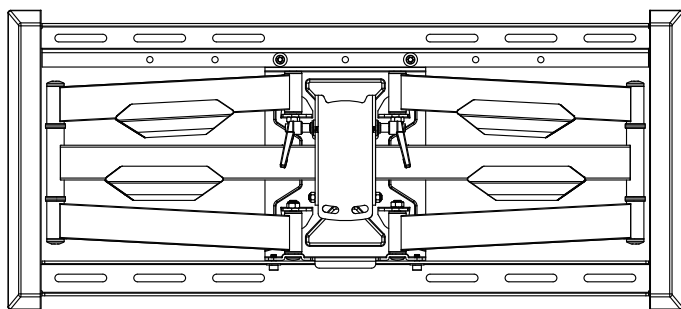

A

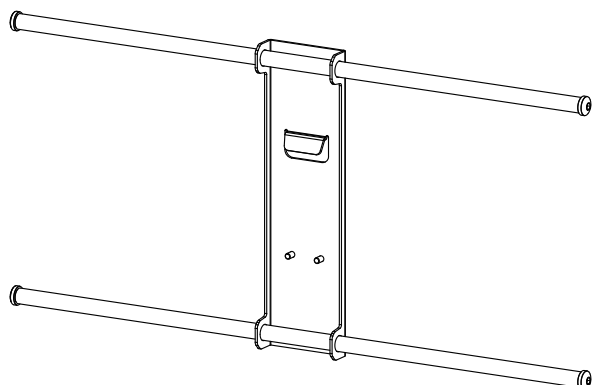
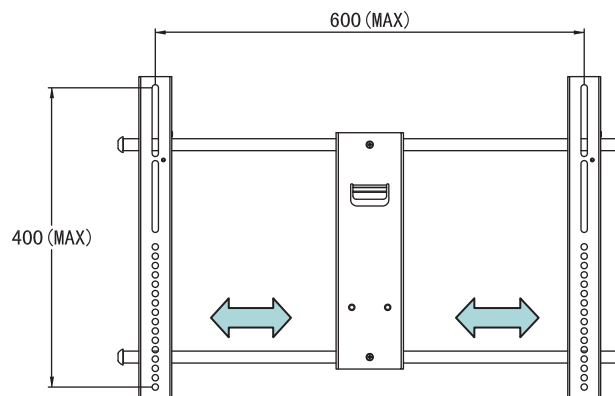

B

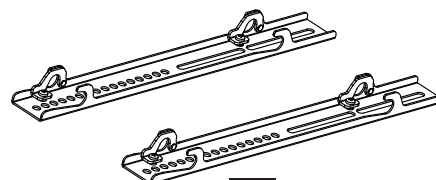

C

PRODUCT COMPONENT PARTS		
Contents	Qty	Description
A	1	Wall Plate and Arm Assembly
B	1	TV Bracket
C	2	Vertical Rails

CORNER MOUNTING INFORMATION

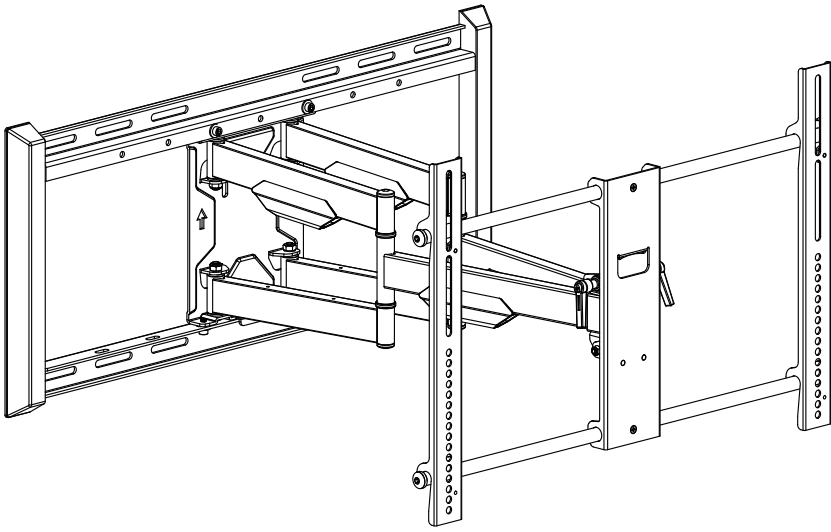

The Large Full Motion Mount can be installed in a corner location when needed. Prior to installing the Mount it is important to determine the appropriate corner wall to install the mount. Please see diagrams below to assist in determining the appropriate wall placement to use.

Drawings below show the Large Full Motion Mount attached to the left and right of the corner. Depending on the desired angle for viewing, please review to determine which wall to mount your TV.

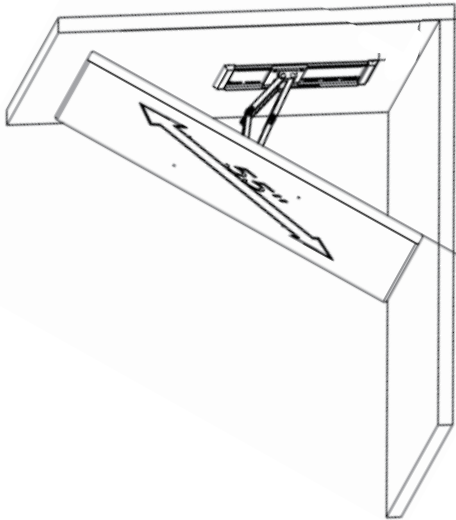

Drawing shows TV mounted to left corner wall

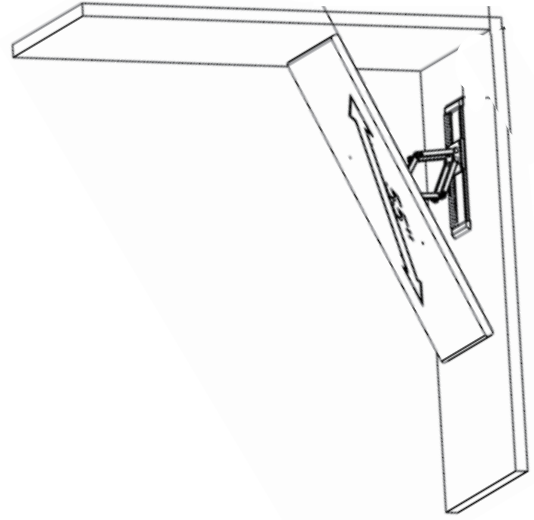

Drawing shows TV mounted to the right corner wall

Maximum angle for corner placement decreases as TV size increases.

STEP 1- CONNECT VERTICAL RAILS TO TV

3 (M8 screws) do not need washer 8

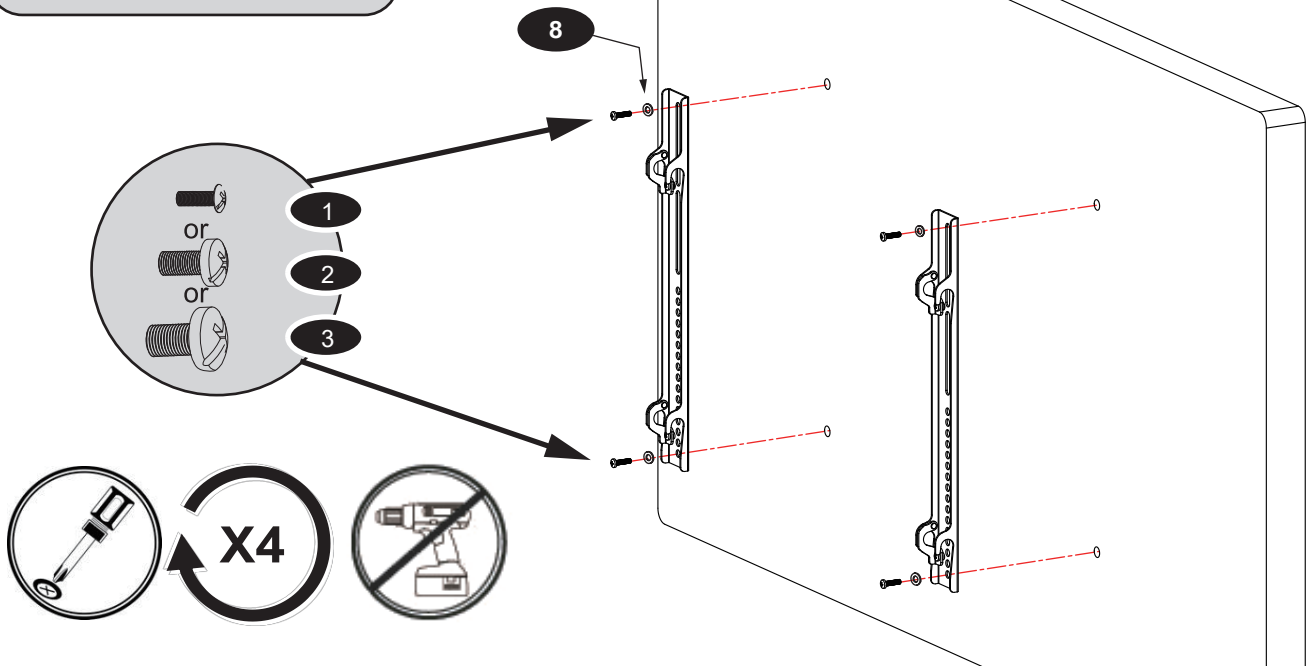

STEP 1- IF MORE CLEARANCE IS NEEDED

Spacers can be used when more clearance is required. Spacers can be stacked 10mm+ 5mm between TV and monitor plate to allow for maximum of 15mm clearance.

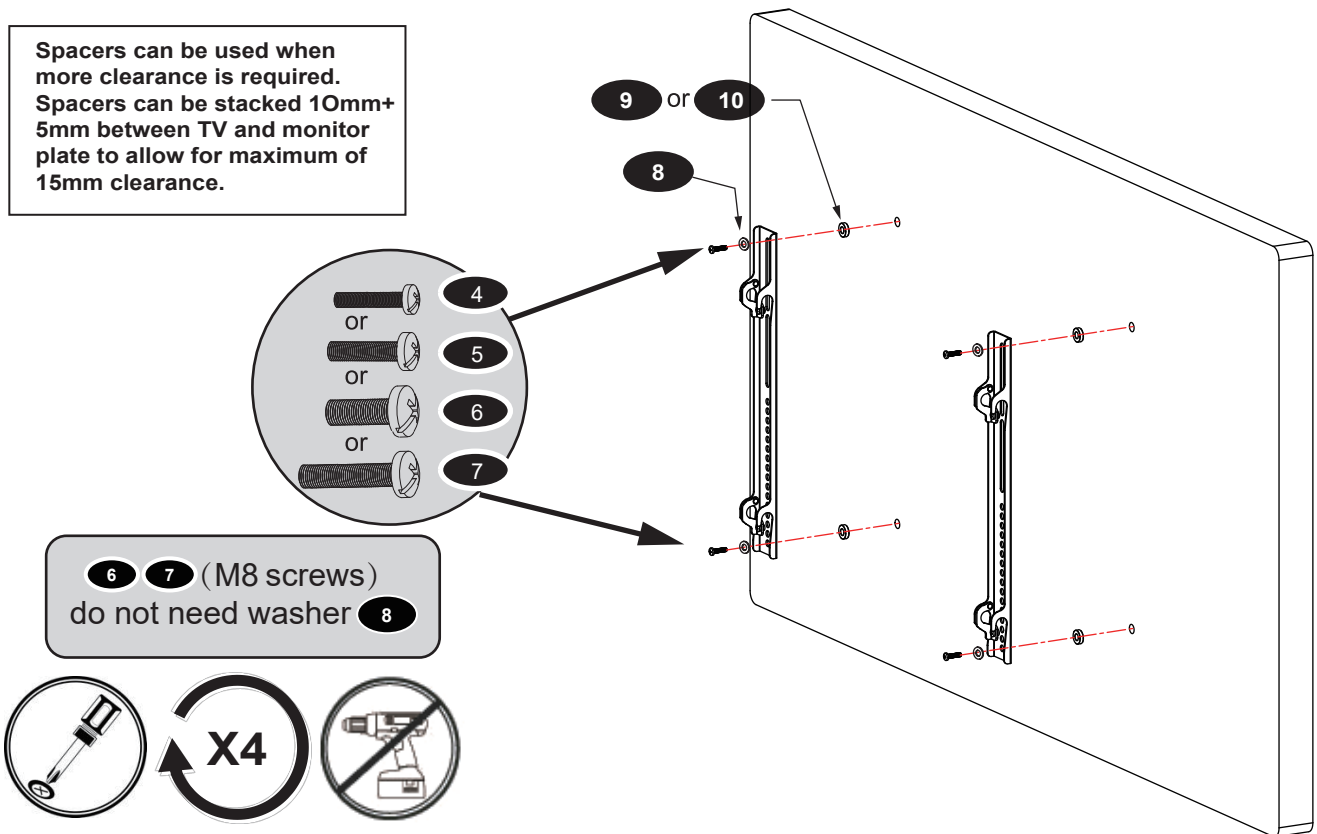

Diagrams show two possible options for using additional washers if hardware screws are too long to properly tighten into the back of the TV.

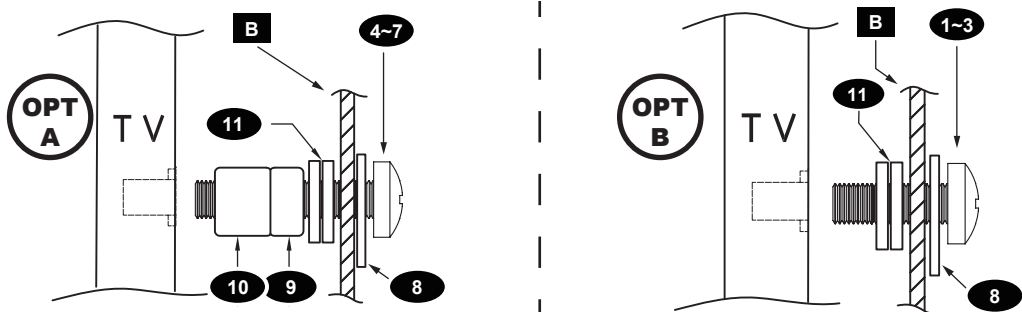

STEP 3A- WOOD STUD INSTALLATION (CONCRETE INSTALLATION SKIP TO 3B)

Find stud and mark edge and center locations

Ubique el panel y marque las ubicaciones de los bordes y el centro.

Repérez l'emplacement d'une poutre, puis marquez l'emplacement des bords et du centre de cette poutre.

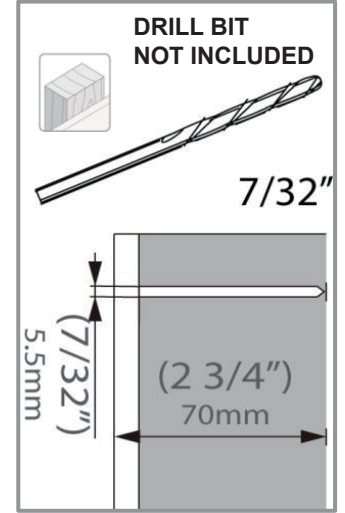
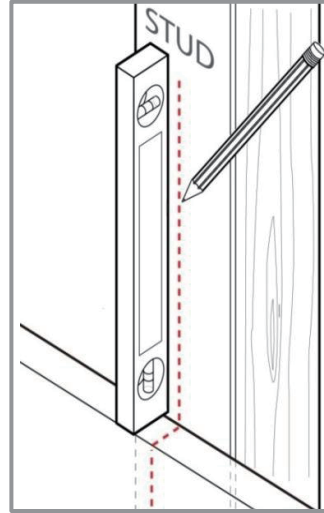
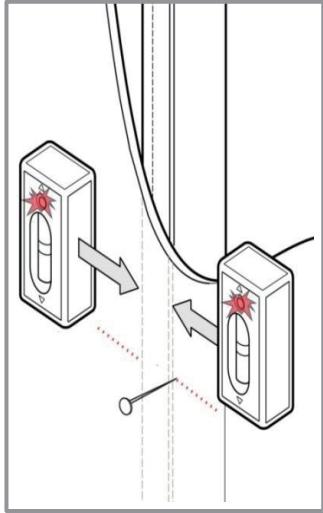

STEP 3A- MARK WALL FOR PILOT HOLES

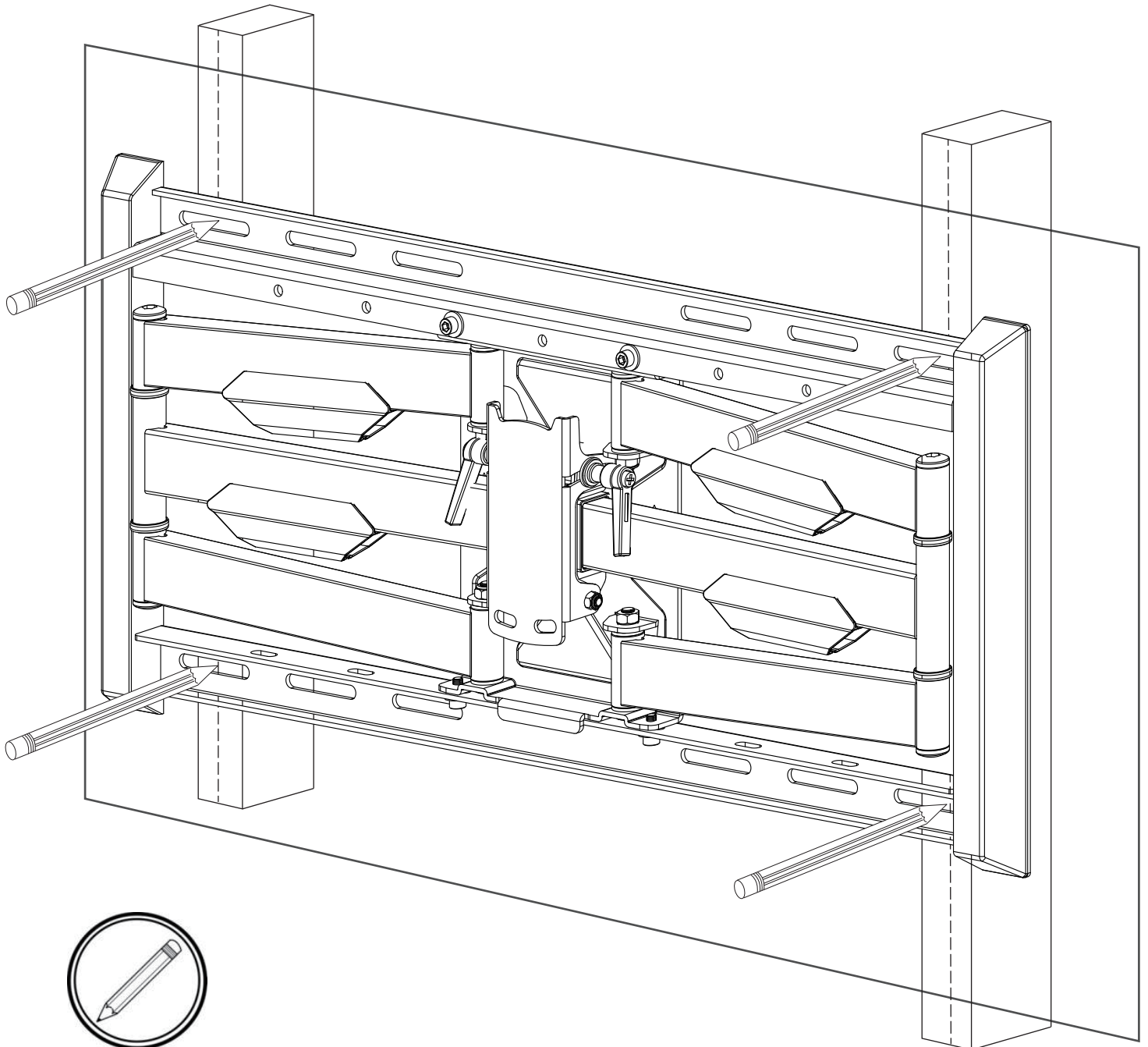

STEP 3A – DRILL PILOT HOLE AND MOUNT WALL PLATE AND ARM ASSEMBLY

Mount wall plate

Coloque la placa de pared
Montez la plaque murale

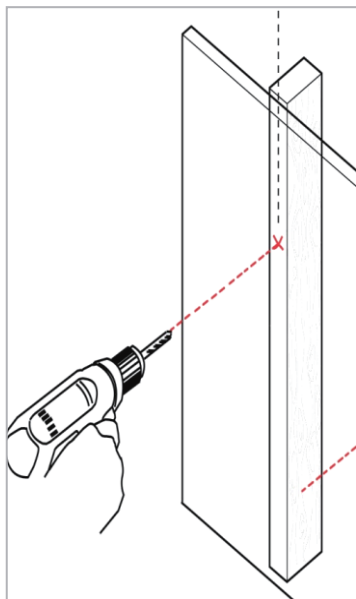

Secure lag bolts with
steel washer to Wall
Plate

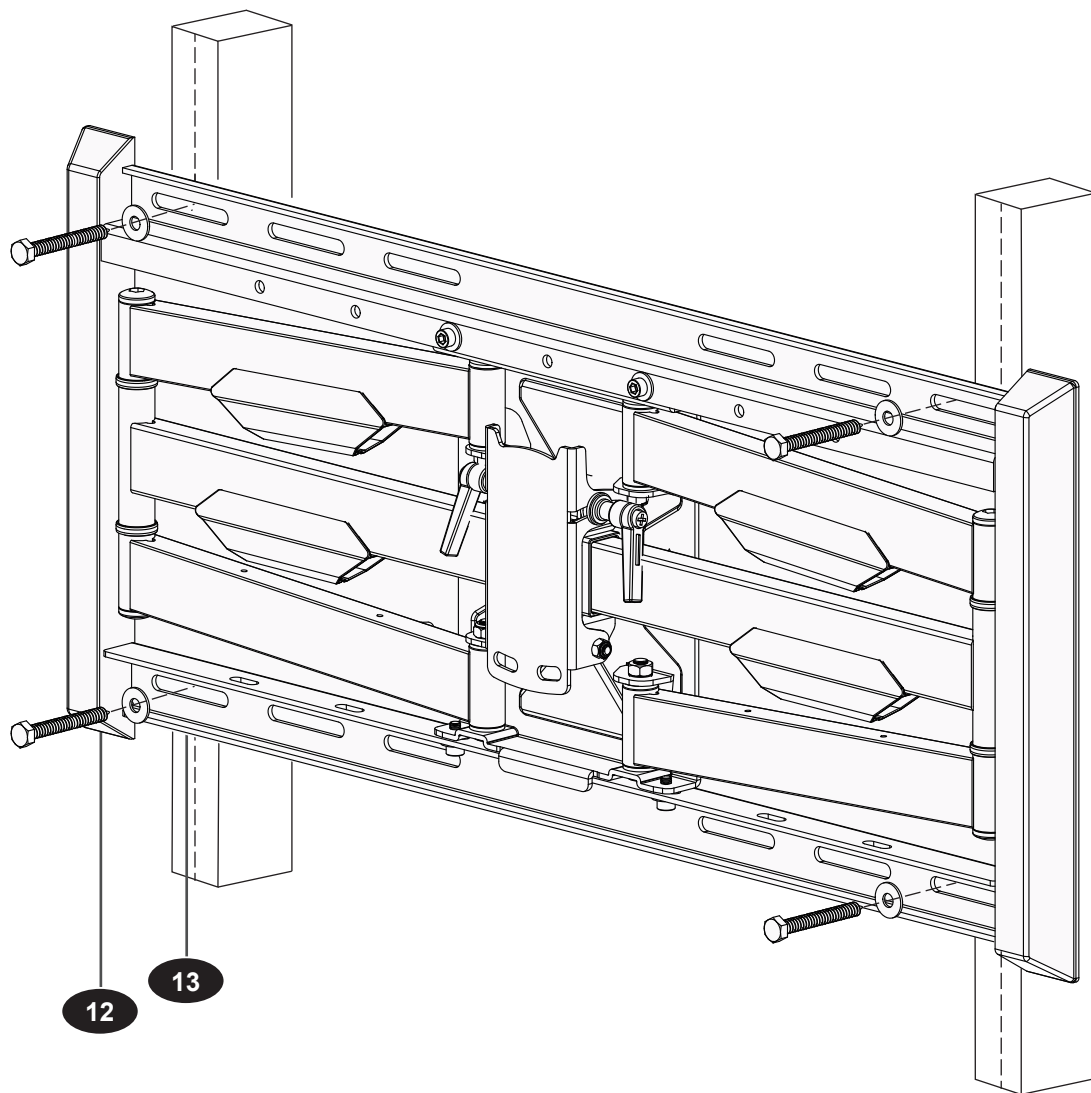
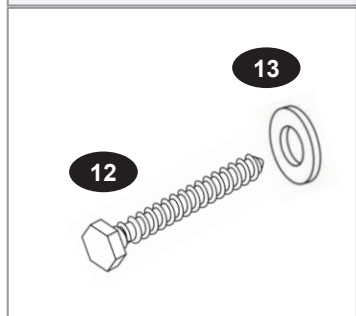

STEP 3B – SOLID CONCRETE INSTALLATION

Solid Concrete

Concreto sólido
Béton massif

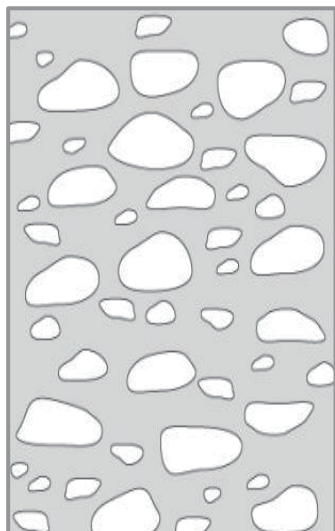

Drill Bit

S. broca
Foret

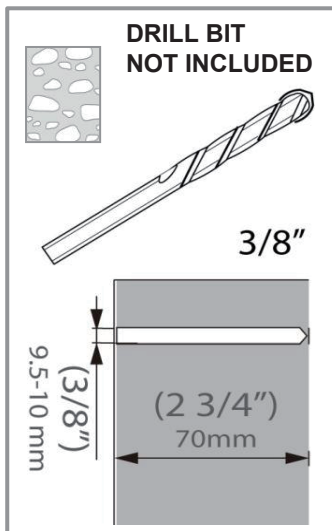

Level

Nivelado
Level

**LEVEL WALL PLATE
WITH INCLUDED
BUBBLE LEVEL AND
MARK HOLES FOR
DRILL BIT PILOT HOLE**

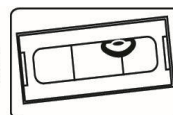
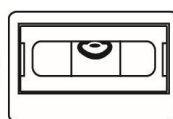

Drill pilot hole

Realice el agujero piloto
Percez le trou de guidage

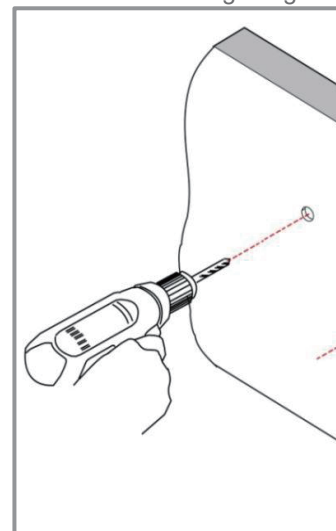

STEP 3B- MARK WALL FOR PILOT HOLES

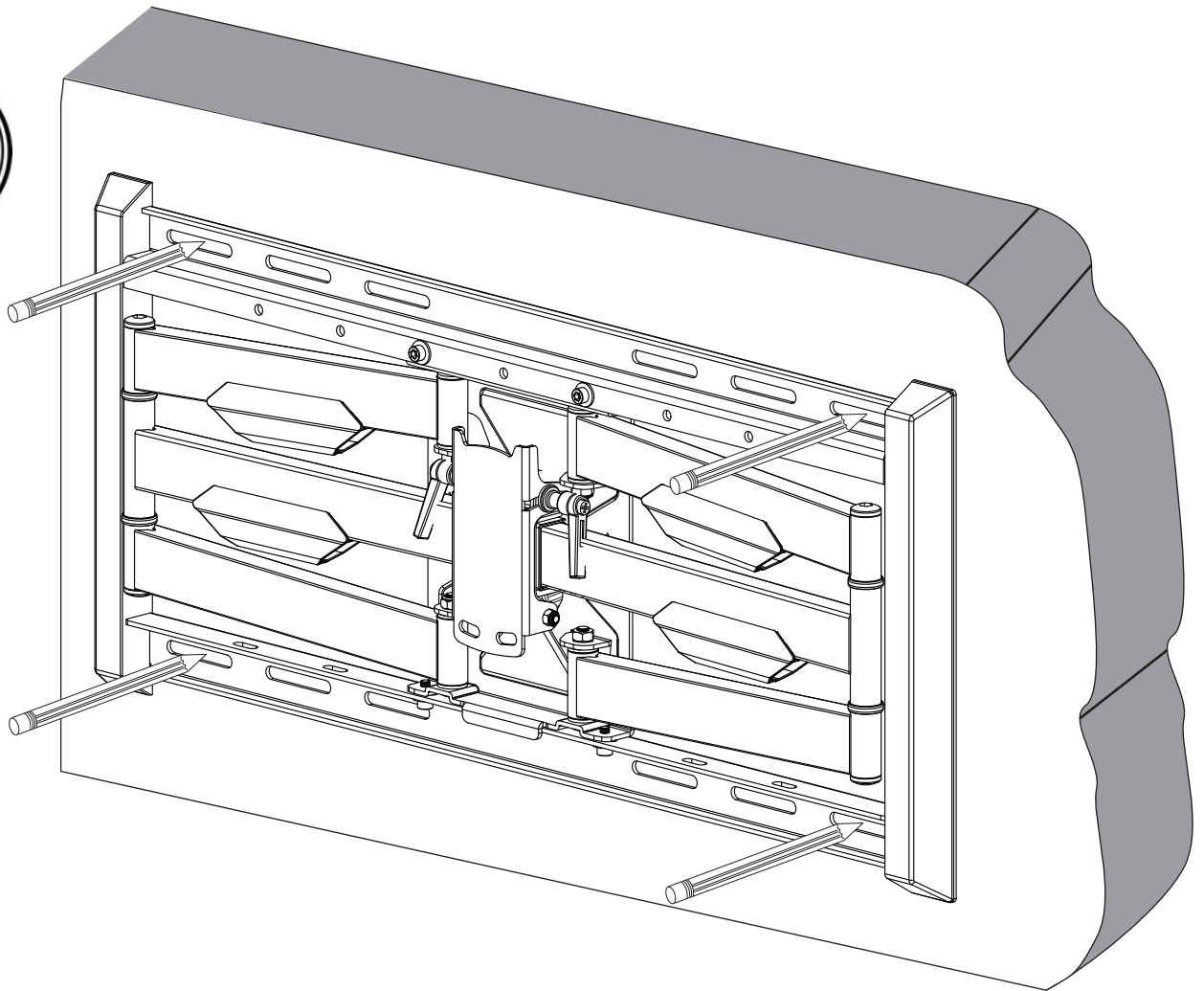

STEP 3B – DRILL PILOT HOLES AND MOUNT WALL PLATE AND ARM ASSEMBLY

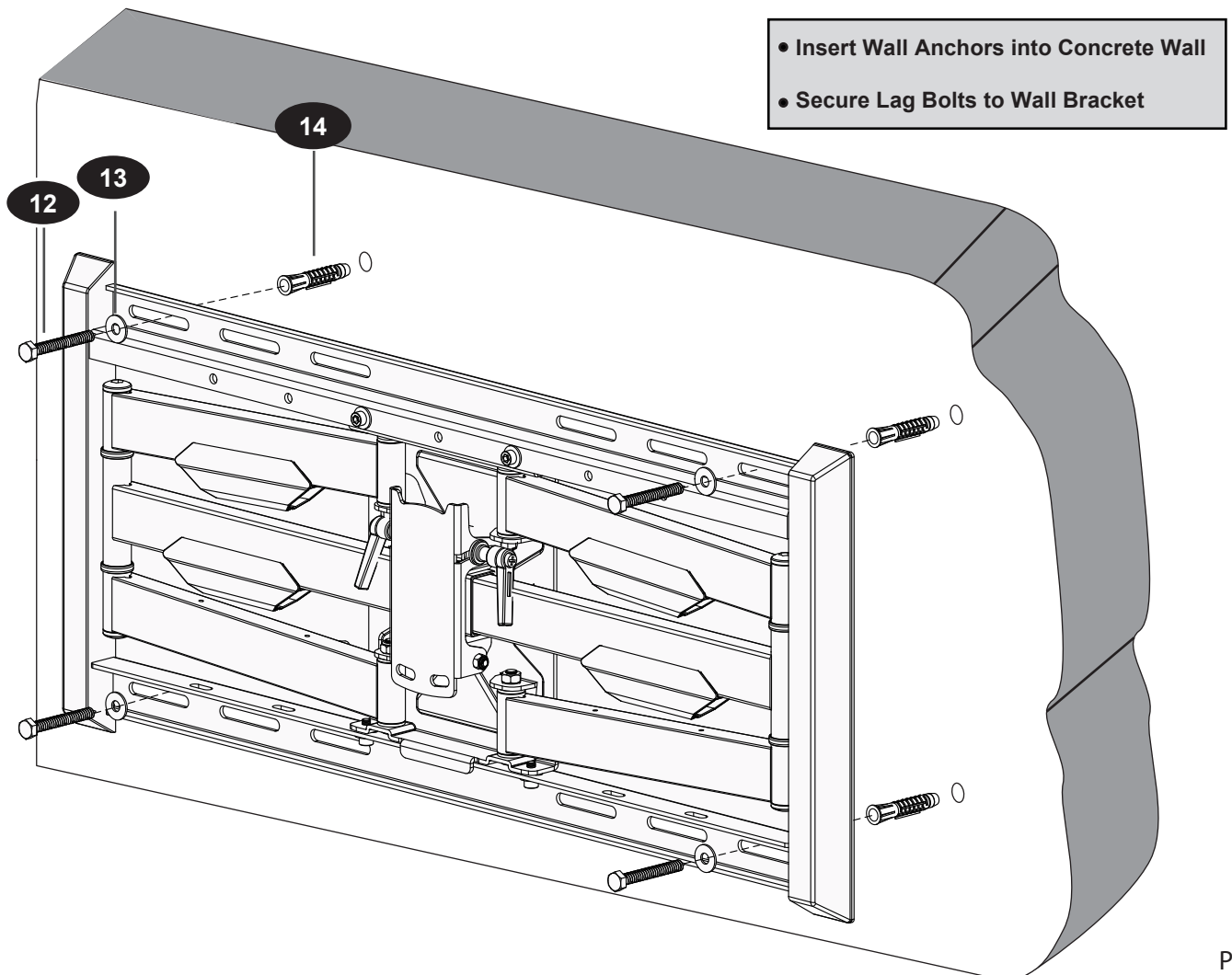

OPTIONAL - ADJUST ARM ASSEMBLY Laterally

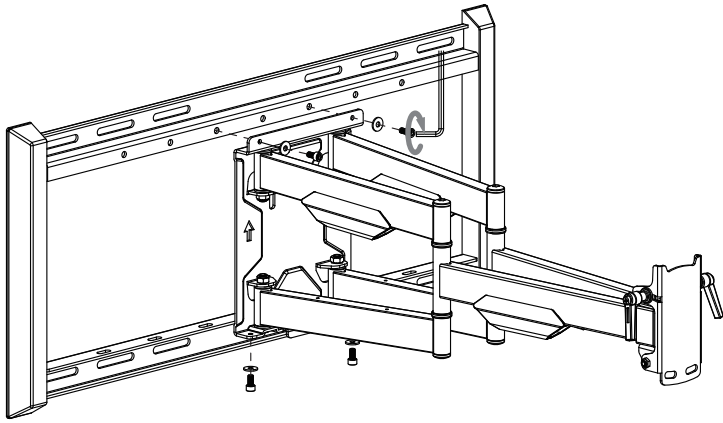

If necessary, you can move the arm assembly laterally to center your TV. Remove 4 bolts as shown at left, move arm assembly to desired location, and reattach arm assembly with the 4 bolts.

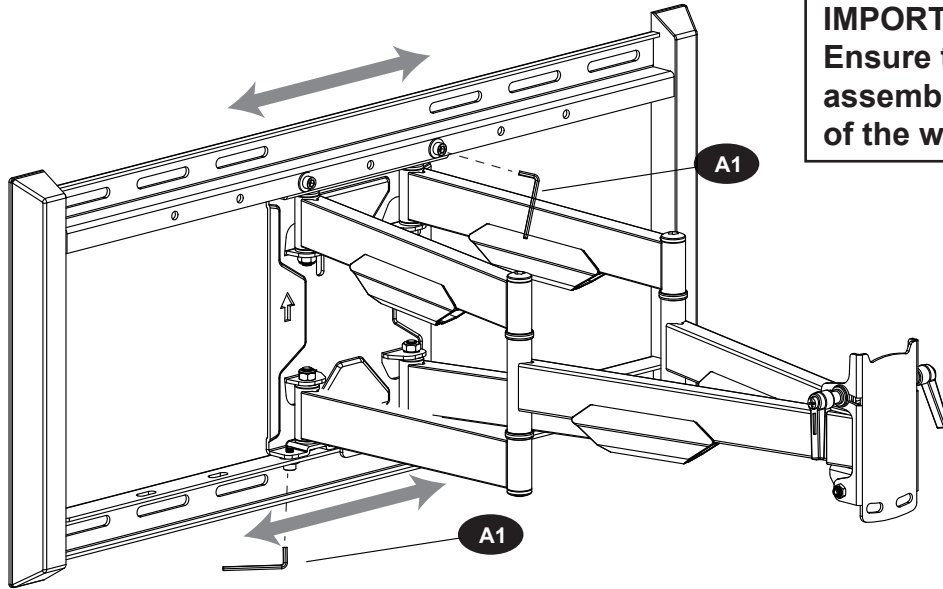

IMPORTANT!
Ensure that the top of the arm assembly tucks **INSIDE** the top of the wall plate.

STEP 4- SECURE TV BRACKET TO ARM ASSEMBLY

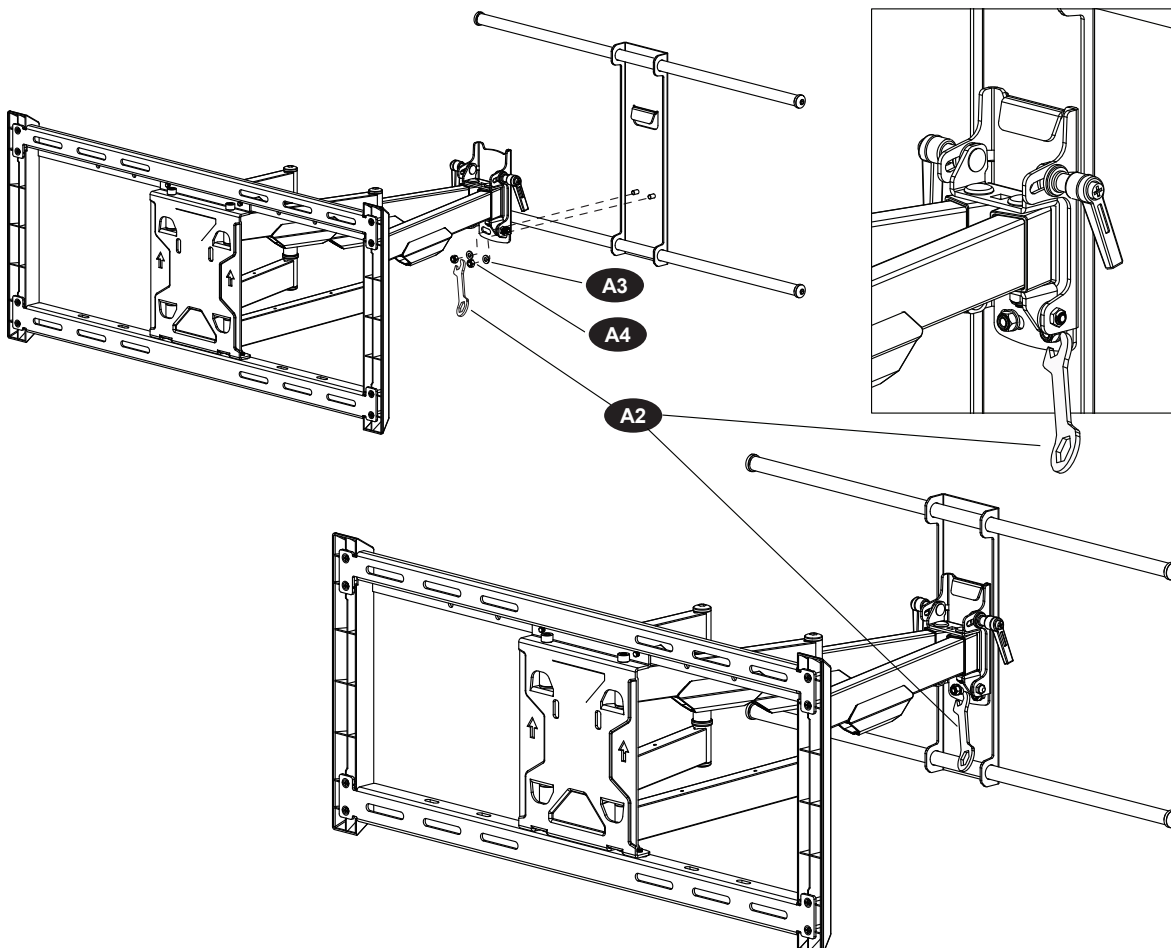

Secure Acorn Nuts and Washers on TV Bracket to Arm Assembly

- A2 Wrench
- A3 M6 Washer
- A4 M6 Nylon Nut

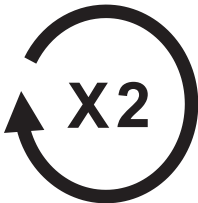

STEP 5- ATTACH TV WITH VERTICAL RAILS TO TV BRACKET



Heavy, Assistance Required

TRES LOURD ! Cette etape requiert deux personnes

!PESADO! Necesitara ayuda para realizar esta operacion

Secure vertical rails to horizontal chrome rods on TV Bracket with pre-installed screws.

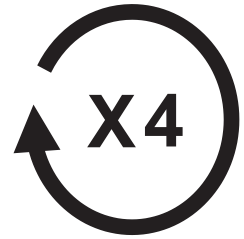
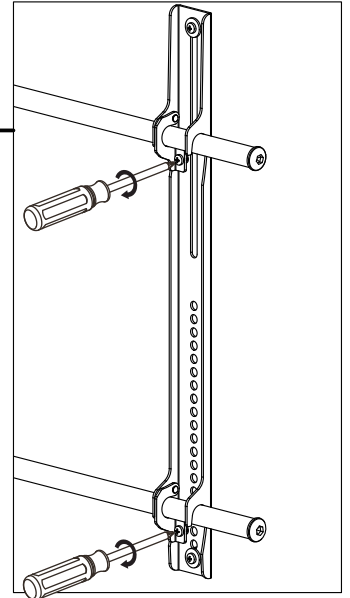
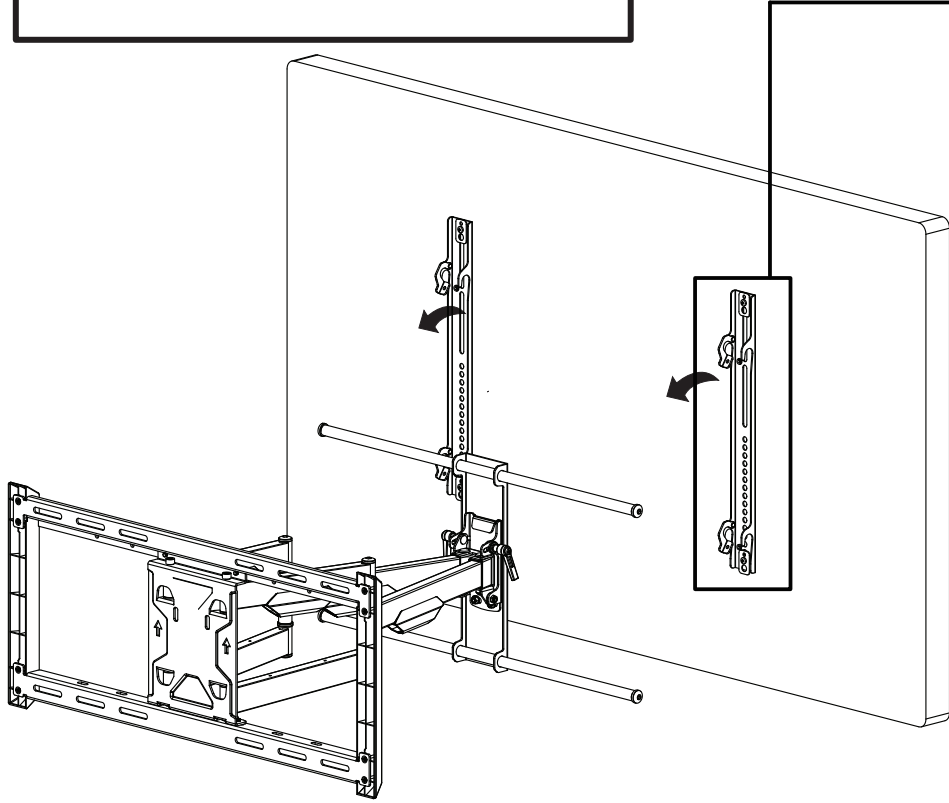

STEP 6 - CENTER TV BRACKET

TV Bracket must be centered (horizontal plane) on back of TV

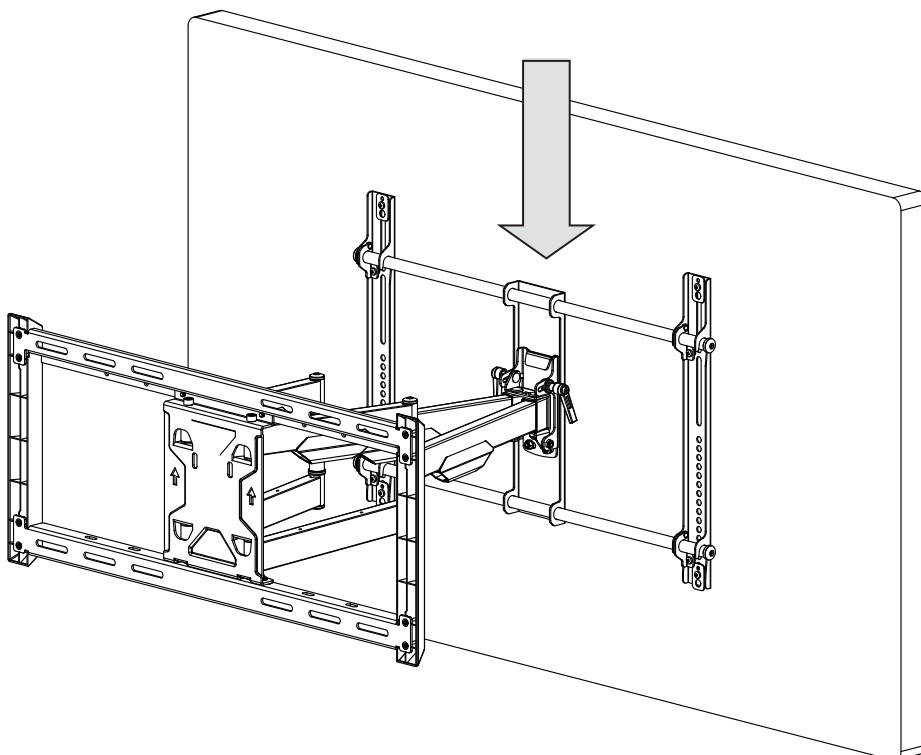

STEP 7 - ADJUST TILT TENSION/ POST INSTALLATION LEVEL

Adjust tilt mechanism tension with ratchet handle lever

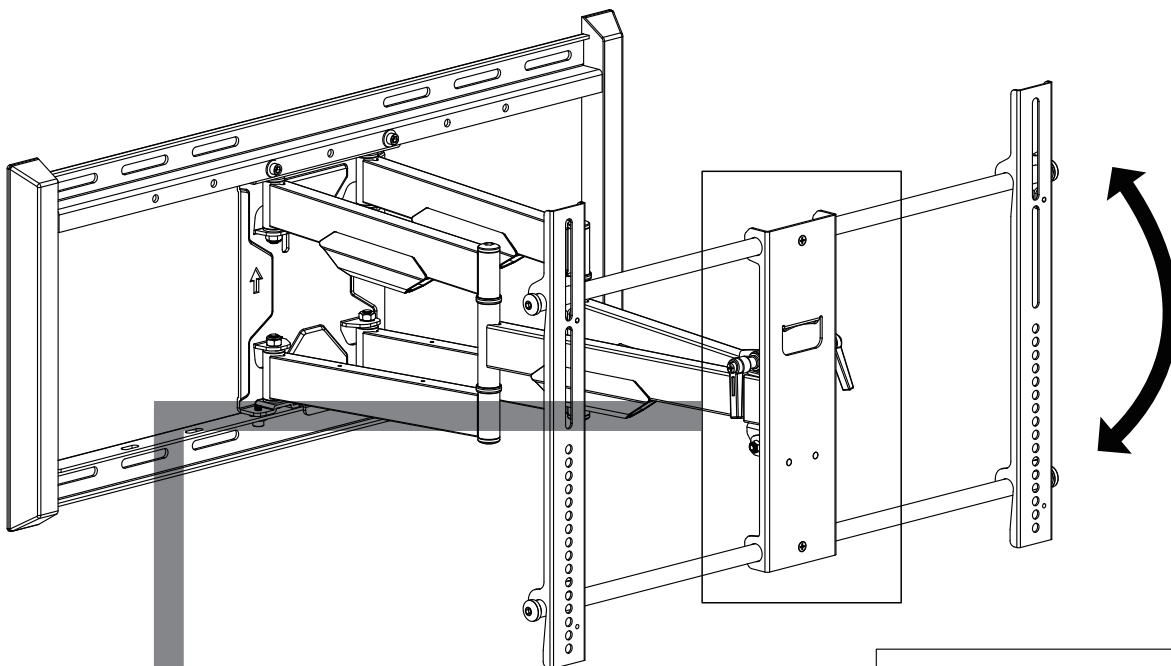

- a) Rotate handle clockwise as far as possible.
- b) Pull handle to side laterally (against spring tension) and rotate counter-clockwise as far as possible.
- c) Repeat steps (a and b) until panel holds desired tilt.

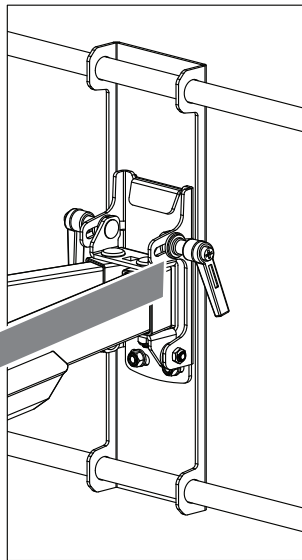

Built-in level feature for post installation correction

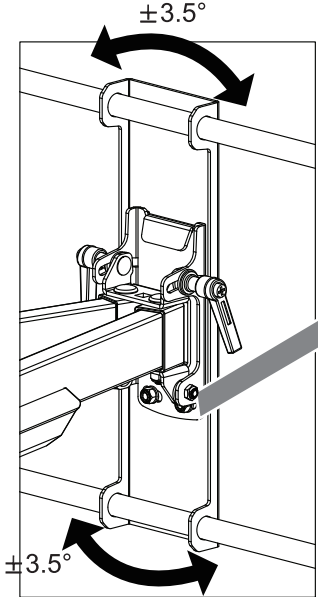

If necessary, adjust the 2 acorn nuts to snug, not tight, tension. Slots on head assembly are wider than bolts. This allows monitor plate and television to move 3.5° in either direction.

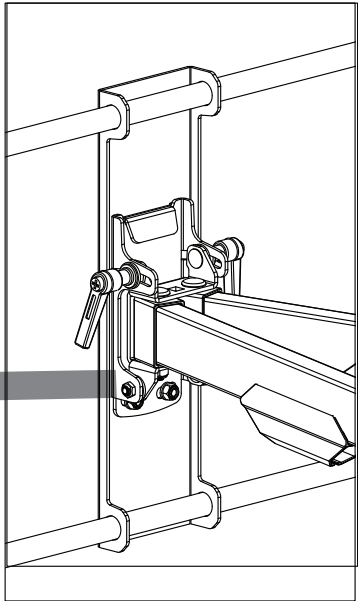

WARRANTY INFORMATION

- This warranty applies to US Residents who purchase from an authorized RED ATOM™ Dealer. RED ATOM products are covered against defects in materials and workmanship for 5 years. RED ATOM will repair or replace the defective component or product, at its sole discretion. Failure to follow product care instructions from RED ATOM will result in void of warranty. To obtain warranty service, contact RED ATOM customer service at info@redatomproducts.com. You must supply a copy of your original receipt. If your product must be shipped to RED ATOM for inspection, you will be responsible for the shipping charges. Replacement product shipped to you will be returned freight pre-paid.
- RED ATOM disclaims any liability for modifications, improper installations, installations over the specified weight range, or failure to follow care instructions provided by RED ATOM. To the maximum extent permitted by law, RED ATOM disclaims any other warranties, expressed or implied, including warranties of fitness for a particular purpose and warranties of merchantability. RED ATOM will not be liable for any damages arising out of the use of, or inability to use, RED ATOM products.
- This warranty gives you specific legal rights, and you may also have other rights which vary from state to state.
- Specifications are subject to change without prior notice.

ESPAÑOL

- Esta garantía se aplica a los residentes de los Estados Unidos que realizaron la compra en un distribuidor autorizado de RED ATOM™. Esta garantía cubre los productos RED ATOM de los defectos de materiales y de mano de obra por un periodo de 5 años. RED ATOM, a su exclusivo criterio, reparará o reemplazará el producto o componente defectuoso. En caso de que no se sigan las instrucciones de RED ATOM para el cuidado del producto la garantía quedará anulada.
- Para obtener el servicio de garantía, comuníquese con el servicio de Atención al cliente de RED ATOM. Escribanos an info@redatomproducts.com. Deberá proporcionar el recibo original. Si fuera necesario enviar el producto a RED ATOM para revisarlo, los gastos de envío correrán por su cuenta. El producto de reemplazo que se le envíe se le devolverá con los gastos de envío pagos.
- RED ATOM no se hace responsable de modificaciones, instalaciones inadecuadas o instalaciones que superen el rango de peso especificado ni se hace responsable en casos en los que no se hayan seguido las instrucciones proporcionadas por RED ATOM. En la medida en que la ley lo permita, RED ATOM no se hace responsable de ninguna otra garantía, expresa o implícita, incluso las garantías de aptitud para un fin determinado o de comercialización. RED ATOM no se hace responsable de ningún tipo de daños causados por el uso de los productos RED ATOM o por el uso inapropiado de dichos productos. RED ATOM no es responsable de los daños incidentales o emergentes. Dentro de éstos se incluyen todo tipo de gastos que pudieran surgir de las reparaciones de productos RED ATOM que no se hayan realizado en RED ATOM.
- Esta garantía le otorga derechos legales específicos. Es posible que además tenga otros derechos que varían según el estado.
- Las especificaciones están sujetas a cambios sin previo aviso.

FRANÇAIS

- Cette garantie s'applique aux résidents des États-Unis qui achètent un produit RED ATOM™ auprès d'un détaillant RED ATOM autorisé. Les produits RED ATOM sont garantis 5 ans contre les défauts de matériaux et de fabrication. RED ATOM se chargera de réparer ou remplacer, à son entière discrétion, tout produit qui s'avèrera défectueux. Le non-respect des directives d'entretien fournies par RED ATOM annulera la garantie.
- Pour obtenir une réparation sous garantie, contactez le service à la clientèle RED ATOM à info@redatomproducts.com. Vous devrez fournir une copie de votre reçu d'achat original. Si votre produit doit être expédié à un centre de réparation RED ATOM pour y être inspecté, vous devrez payer les frais de port. Le produit de remplacement vous sera envoyé en port payé. RED ATOM rejette toute responsabilité relativement à quelque problème pouvant être associé à une modification d'un produit, à une mauvaise installation ou à une installation ne respectant pas les limites de charge, ou du non-respect des directives d'entretien fournies par RED ATOM. Sous réserve des lois en vigueur, RED ATOM réfute toute autre garantie expresse ou implicite, notamment toute garantie de commercialisation ou de convenance à un usage quelconque. RED ATOM réfute toute responsabilité pour des dommages résultants de l'utilisation ou de l'impossibilité d'utiliser des produits RED ATOM. RED ATOM réfute également toute responsabilité pour quelque dommage accessoire ou indirect. Ceci s'applique notamment aux frais de main d'œuvre pour la réparation de produits RED ATOM par une personne ne travaillant pas pour RED ATOM.
- Cette garantie vous accorde des droits juridiques spécifiques, mais il est possible que vous ayez également d'autres droits selon votre lieu de résidence.
- Les spécifications sont susceptibles d'être modifiées sans préavis.

NEED HELP?

info@redatomproducts.com

